

PROCESS REFRACTOMETER  
FOR CONCENTRATION  
MEASUREMENT OF CHEMICALLY  
AGGRESSIVE LIQUIDS

**VAISALA**



Vaisala K-PATENTS® Process Refractometer PR-23-W/M

# TYPICAL APPLICATIONS

The Saunders Body PR-23-W and Teflon Body PR-23-M Refractometers provide accurate means for measuring liquid concentrations in chemically aggressive solutions that corrode, foul or otherwise destroy metal parts as well as in ultra-pure fine chemical processes, where metal parts cannot be used.

## CHLOR-ALKALI INDUSTRY

## CORROSIVE CHEMICALS

## ULTRA PURE FINE CHEMICALS

## ELECTRONIC CHEMICALS

Acetic acid  $\text{CH}_3\text{COOH}$ , Ammonium fluoride  $\text{NH}_4\text{F}$ , Ammonium hydroxide  $\text{NH}_4\text{OH}$ , Ammonium sulphate  $(\text{NH}_4)_2\text{SO}_4$

Calcium hypochlorite  $\text{Ca}(\text{ClO})_2$ , Copper chloride  $\text{CuCl}_2$ , Citric acid  $\text{C}_6\text{H}_8\text{O}_7$ , Chromic acid  $\text{CrO}_3$

Ferric chloride  $\text{FeCl}_3$ , Fluosilic acid, Formic acid  $\text{HCO}_2\text{H}$

Hydrochloric acid  $\text{HCl}$ , Hydrofluoric acid  $\text{HF}$ , Hydrogen peroxide  $\text{H}_2\text{O}_2$ , Buffered HF (BHF), Aqua Regia  $\text{HNO}_3/\text{HCl}$

Lactic acid  $\text{C}_2\text{H}_4(\text{OH})\text{COOH}$

Magnesium chloride  $\text{MgCl}_2$ , Nickel chloride  $\text{NiCl}_2$ , Nitric acid  $\text{HNO}_3$

Phosphoric acid  $\text{H}_3\text{PO}_4$ , Potassium carbonate  $\text{K}_2\text{CO}_3 \cdot 1\frac{1}{2} \text{H}_2\text{O}$ , Potassium hydroxide  $\text{KOH}$ , Potassium thiocyanate  $\text{KSCN}$ , Potassium nitrate  $\text{KNO}_3$

Sodium bicarbonate  $\text{NaHCO}_3$ , Sodium carbonate  $\text{Na}_2\text{CO}_3$ , Sodium chloride  $\text{NaCl}$ , Sodium dichromate  $\text{Na}_2\text{Cr}_2\text{O}_7 \cdot 2\text{H}_2\text{O}$ , Sodium hydroxide  $\text{NaOH}$ , Sodium hypochlorite  $\text{NaClO}_2$ , Sulphuric acid  $\text{H}_2\text{SO}_4$  and more.



Vaisala K-PATENTS® Process Refractometer PR-23-W/M

# INSTALLATION

2" pipe size



3" pipe size



4" pipe size



## SAUNDERS BODY REFRACTOMETER PR-23-W

The Saunders Body Refractometer PR-23-W is designed for use in chemically aggressive solutions and ultra-pure fine chemical processes in large-scale production and in large pipelines (diameter 50, 80 or 100mm/2", 3" or 4").

The PR-23-W refractometer is delivered with a Saunders (diaphragm) valve body and can be mounted either in a vertical or horizontal pipe. The Saunders body material is Graphite cast iron, which provides a solid mechanical base for the sensor installation.

The cast iron is lined with 3mm ETFE (Ethylene tetrafluoroethylene) fluoroplastic that gives the body a high chemical resistance. The sensor wetted parts materials are Teflon® PTFE (Polytetrafluoroethylene) and Sapphire ( $Al_2O_3$ ). The material of the sensor cover is stainless steel AISI 316 L.

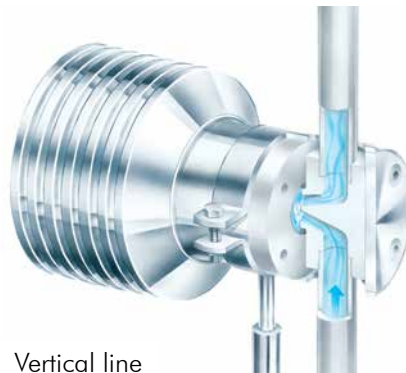

Vertical line



Horizontal line

## TEFLON BODY REFRACTOMETER PR-23-M

The Teflon Body Refractometer PR-23-M is designed for small pipe sizes.

The sensor wetted parts Teflon® PTFE or Kynar® PVDF (Polyvinylidene fluoride), Sapphire ( $Al_2O_3$ ), and Kalrez® are carefully selected because they have high chemical and mechanical resistance.

The external materials AISI 316L (sensor cover) and polyamid 6.6 (electrical connector) withstand chemically aggressive gases and splashes of the process liquid.

The measurement accuracy of either Refractometer model is not influenced by particles, bubbles, colour or temperature changes of the process liquid.



# DIGITAL MEASUREMENT PRINCIPLE

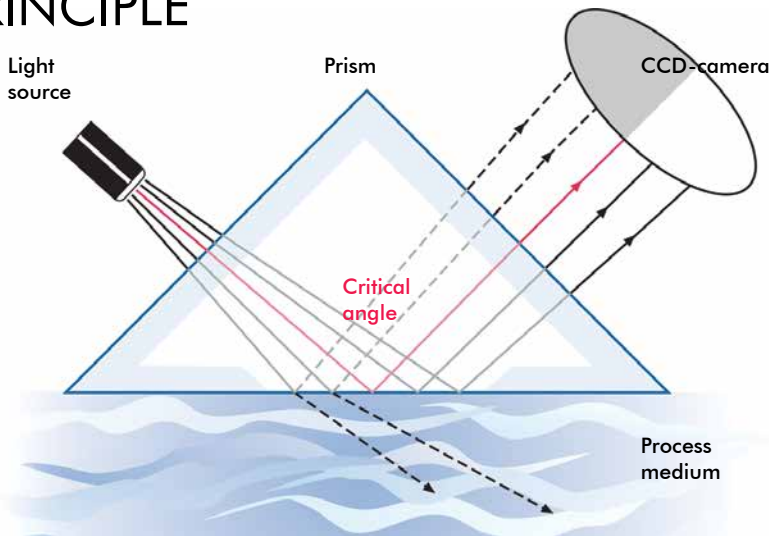

The light source sends light against the interface between the prism and the process solution, where the rays meet the surface at different angles.

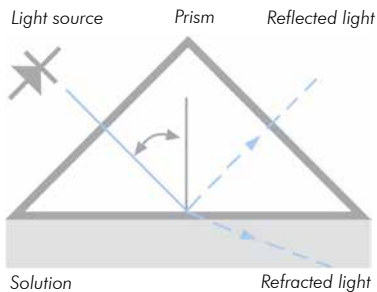

Depending on the angle, some rays are totally reflected. Some rays are only partially reflected, and most of the light is refracted into the process solution.

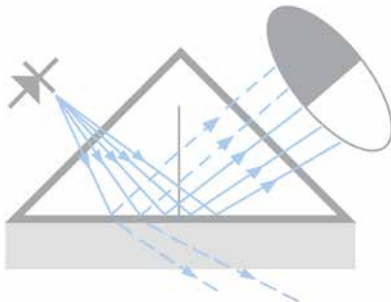

Thus an optical image with a dark sector and a light sector is created.

The angle corresponding to the shadow line is called the Critical Angle of Total Reflection. The Critical Angle is a function of the refractive index and hence the concentration of the solution.

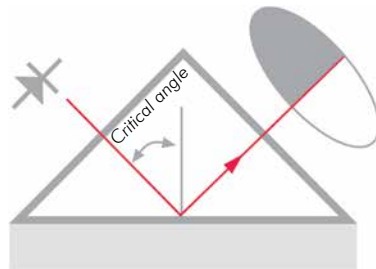

A digital CCD-camera detects the optical image and the shadow line. The camera transforms the optical image point-by-point to an electrical signal. The exact shadow line position is located and converted to a reading in refractive index.

A built-in temperature sensor measures the temperature on the surface of the process liquid. The indicating transmitter converts the refractive index and temperature to concentration units.

The diagnostics program ensures that the measurement is reliable.

# OPERATION

The Refractometer PR-23-W/M sensor is factory calibrated to measure refractive index  $n_D$  and temperature  $T$  in standard units. Each sensor has identical calibration  $n_D = 1.32 \dots 1.53$  (corresponding to 0-100% b.w.). One or two sensors can be connected to one Indicating transmitter.

Because the sensors have identical calibration, and each sensor gives Refractive Index  $n_D$  and temperature as output, all sensors can be freely interchanged without optical calibration or parameter changes.

Each sensor comes with a calibration certificate comparing a set of standard liquids to the actual sensor output. The calibration and accuracy can be easily verified on-site with certified refractive index liquids and the documented verification procedure.

# REMOTE USABILITY

The PR-23-W/M ease-of-use is significantly improved by a built-in web server that can be accessed via Ethernet. It is possible to obtain a remote display with real-time measurement data and diagnostics, and remotely alter instrument configuration settings or update program versions without having to go to the field.

Only a cross-over cable and data acquisition software are needed for collecting the data from a PR-23-W/M refractometer. The communication is built on standard protocols (UDP/IP) and offer ready-to-install software for the data acquisition.

Our data acquisition software is expandable in case the user wants to modify the program. The program is written in Java and is therefore system independent. It can be tailored to almost any computing environment.

# DESIGN

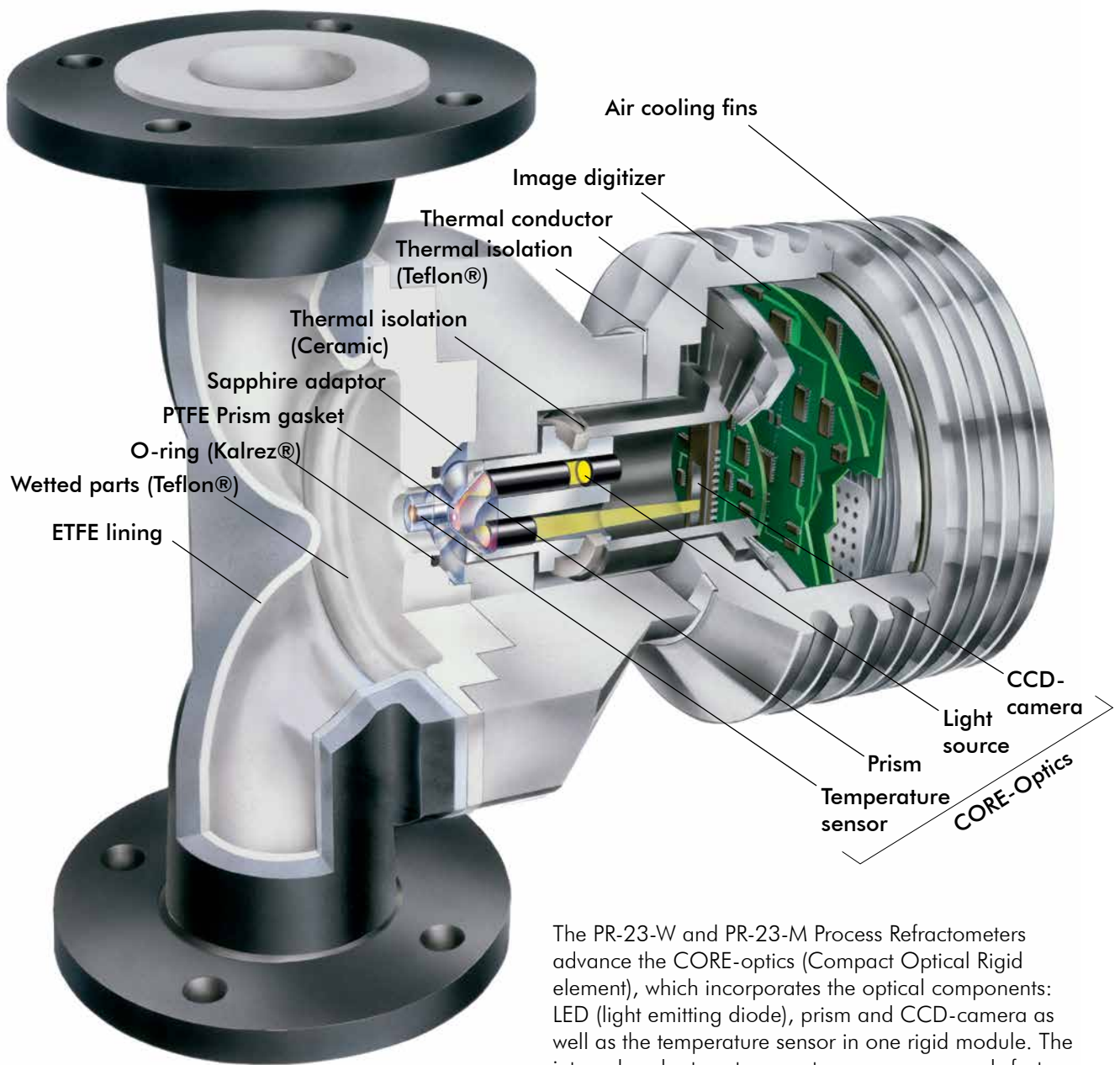

The PR-23-W and PR-23-M Process Refractometers advance the CORE-optics (Compact Optical Rigid element), which incorporates the optical components: LED (light emitting diode), prism and CCD-camera as well as the temperature sensor in one rigid module. The integral probe type temperature sensor responds fast to the changes of the process liquid temperature. The CORE-optics module is isolated from the sensor body and therefore external forces like pressure, flow and temperature changes do not influence the measurement.

# SPECIFICATIONS

## SENSOR PR-23-W

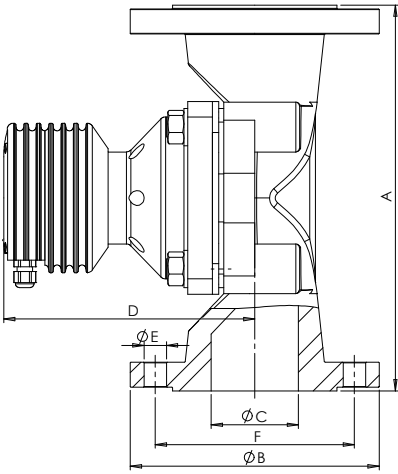

Saunders valve body	Flange size	A	B	C	D	E	F
SVB-A020	ANSI 2" 150psi	196 (7.72)	152.4 (6)	47 (1.85)	189 (7.40)	19.1 (0.75)	120.7 (4.75)
SVB-D060	DN50 10bar	230 (9.06)	166 (6.53)	50 (1.97)	189 (7.40)	18 (0.71)	125 (4.92)
SVB-A050	JIS 10k 50A	156 (6.1)	61 (2.4)		190 (7.5)		120 (4.72)
SVB-A030	ANSI 3" 150psi	260 (10.24)	190.5 (7.5)	78 (3.07)	205 (8.07)	19.1 (0.75)	152.4 (6)
SVB-D080	DN80 10bar	310 (12.2)	200 (7.87)	80 (3.15)	205 (8.07)	18 (0.71)	160 (6.30)
SVB-A060	JIS 10k 80A	182 (7.2)	80 (3.15)	80 (3.15)	190 (7.5)		150 (5.9)
SVB-A040	ANSI 4" 150psi	311 (12.24)	228.6 (9)	92 (3.62)	256 (10.08)	19.1 (0.75)	190.5 (7.5)
SVB-D100	DN100 10bar	350 (13.78)	220 (8.66)	100 (3.94)	256 (10.08)	18 (0.71)	180 (7.09)
SVB-A100	JIS 10k 100A	210 (8.27)	115 (4.54)		190 (7.5)		175 (6.89)

## SENSOR PR-23-M

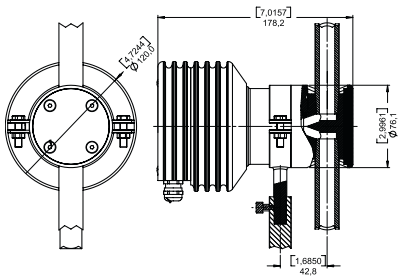

## INDICATING TRANSMITTER DTR

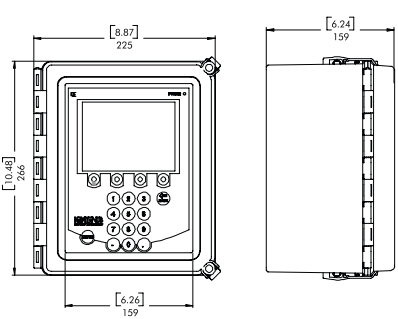

Refractive Index range, standard:	Full range, $n_D 1.3200 \dots 1.5300$ (corresponds to 0...100% b.w.), sapphire prism
Refractive Index range, option:	$n_D 1.2600 \dots 1.4700$ , sapphire prism
Accuracy:	$n_D \pm 0.0002$ , typically corresponds to $\pm 0.1\%$ b.w. Repeatability $n_D \pm 0.0001$ , typically corresponds to $\pm 0.05\%$ b.w.)
Speed of response:	1s undamped, damping time selectable up to 5 min
Patented CORE-Optics:	No mechanical adjustments and digital measurement with 3648 pixel CCD element, sodium D-line light emitting diode (LED), built-in Pt-1000 temperature sensor
Temperature compensation:	Automatic, digital compensation
Instrument verification:	With standard $n_D$ liquids and the documented procedure (ISO 9000)
Ambient temperature:	Sensor: $-20 \text{ }^\circ\text{C} \dots 45 \text{ }^\circ\text{C}$ ( $-4 \text{ }^\circ\text{F} \dots 113 \text{ }^\circ\text{F}$ ); Indicating transmitter: $0 \text{ }^\circ\text{C} \dots 45 \text{ }^\circ\text{C}$ ( $32 \text{ }^\circ\text{F} \dots 122 \text{ }^\circ\text{F}$ )
Process temperature:	$-20 \text{ }^\circ\text{C} \dots 130 \text{ }^\circ\text{C}$ ( $-4 \text{ }^\circ\text{F} \dots 266 \text{ }^\circ\text{F}$ )
Sensor protection class:	IP67, Nema 4X
Approvals for hazardous locations:	Non-Sparking/Non-Incendive version: ATEX certified for Zone 2 area, Ex II 3 G, EEx nA IIC T4 Gc; FM certified for Class I, Div. 2, Groups A, B, C & D hazardous locations, T6; CSA certified for Class I, Div. 2, Groups A, B, C & D, T4; IECEx certified, Ex nA IIC T4 Gc Intrinsically safe version: ATEX certified for Zone 0 area, Ex II 1 G, EEx ia IIC T4 Ga; FM certified for Class I, Div. 1, Groups A, B, C & D, T4 (for U.S.A. and Canada); IECEx certified, Ex ia IIC T4 Ga
Approval for electrical safety:	cCSAus certified, Equipment Class I, Poll. Deg. 2 / Transmitter, Poll. Deg. 3 / Sensor, Install. Cat. II

<b>SENSOR PR-23-W:</b>	Process connection with ETFE (Ethylene tetrafluoroethylene) lined Saunders (diaphragm) valve body 2", 3" or 4"; valve body material Graphite cast iron
Saunders body process connection:	DIN-flange DN50 PN 16/DIN-flange DN80 PN 16/DIN-flange DN100 PN 16/ANSI-flange 4" 150 lbs/ANSI-flange 3" 150 lbs/ANSI-flange 2" 150 lbs / JIS-flange 10k 50A/ JIS-flange 10k 80A/ JIS-flange 10k 100A

Sensor wetted parts:	ETFE (Ethylene tetrafluoroethylene) lining, prism gasket Teflon® PTFE, prism sapphire, O-ring Kalrez, adaptor sapphire
Sensor weight:	with 2" Saunders body 15 kg (33 lbs)/3" 26 kg (57 lbs)/4" 33 kg (73 lbs)
Process pressure:	max. 10 bar (145 psi)

<b>SENSOR PR-23-M:</b>	Process connection with Thread G1/2" (F) or Thread NPT 1/2" (F)
Sensor wetted parts:	Teflon® PTFE or Kynar® PVDF (Polyvinylidene fluoride), prism gasket Teflon® PTFE, prism sapphire, O-ring Kalrez, adaptor sapphire
Sensor weight:	5.5 kg (12 lbs)

<b>INDICATING TRANSMITTER DTR:</b>	
Display:	320x240 pixel graphical LCD with LED backlight, keypad with 8 membrane keys
Current output:	Two independent current outputs, 4-20 mA, max. load 1000 Ohm, galvanic isolation 1500 VDC or AC (peak), hold function during prism wash
Fieldbus and industrial Ethernet connectivity:	Through Fieldbus converter to Modbus/TCP, Modbus RTU and Ethernet/ IP networks
Power:	AC input 100-240 VAC/50-60 Hz, optional 24 VDC, 30 VA
Alarms/Wash relays:	Two built-in signal relays, max. 250 V/3 A
Sensor connectivity:	One or two sensors can be connected to one DTR. Sensors independent with own parameter sets and usable in different applications. Two current outputs configurable independently to indicate process concentration or temperature of either sensor.

Indicating transmitter weight:	4.5 kg (10 lbs)
Transmitter protection class:	Polycarbonate enclosure IP66, Type 4X (indoor use); AISI 304 Stainless steel enclosure IP66 (Indoor use)

<b>INTERCONNECTING CABLE:</b>	IEC 61158-2 compliant two-wire cable
Interconnecting cable length:	Standard 10 m (33 ft), max. 200 m (660 ft). Cable fittings to Indicating transmitter: European cable glands M20x1.5 or US conduit hubs
PATENTS:	See <a href="http://www.kpatents.com">www.kpatents.com</a>

<b>ORDERING INFORMATION:</b>	<ul style="list-style-type: none"> <li>- Sensor type and process connection</li> <li>- Desired scale</li> <li>- Properties of process solution</li> <li>- Process temperature range</li> <li>- Process pipe size</li> <li>- Process flow rate</li> <li>- Supply voltage and frequency</li> <li>- Options and accessories</li> </ul>
------------------------------	---



[www.vaisala.com](http://www.vaisala.com)

Please contact us at  
[www.vaisala.com/requestinfo](http://www.vaisala.com/requestinfo)

Ref. B211889EN-A © Vaisala 2020

We reserve right to technical alterations.