

A COMPACT PROCESS
REFRACTOMETER
FOR CONCENTRATION
MEASUREMENT OF LIQUIDS

VAISALA



Vaisala K-PATENTS® Process Refractometer PR-23-GC

TYPICAL APPLICATIONS

CHEMICALS

Acetic acid, Acrylate, Amine oxide, Amino acid, Ammonium fluoride, Ammonium hydroxide, Ammonium nitrate, Ammonium sulphate, Caustic soda, Cellulose derivatives, Citric acid, Copper chloride, Chromium trioxide (or Chromic acid), Ethylene glycol, Formaldehyde, Formic acid, Glycerol, Hydrogen peroxide, Iron chloride, Lactic acid, Lubricating oils, Nickel chloride, Nitric acid, Oleum, Polyamides, Polycarbonates, Polyethylene, Resins, Sodium bicarbonate, Sodium dichromate, Sodium gluconate, Sodium hydroxide, Styrenes, Sulphuric acid, Urea, etc.

PLASTICS AND FIBERS

Acetate, Acrylics, Adipic acid, Caprolactam, Cyclohexanol, Cyclohexanon, Dimethylterephthalate, Dimethylformamide, Fiberglass, Hexamethylene diamine, Nylon salt, Polyamides, Polyesters, Rayon, Spandex, Vinyls. Finishing, coating and dyeing mediums of textiles.

OIL AND GAS

Sulfuric acid alkylation: Acid catalyst, spent acid recovery; Amine gas treating: Amine solvent in the removal of H₂S (hydrogen sulfide) and CO₂ (carbon dioxide)

KRAFT PULP

Brown stock washing: dissolved dry solids (lignin) from washed pulp suspensions after cooking, before and after oxygen delignification and before bleaching.

METAL MACHINING

Cutting fluids.

SALTS AND SODIUM COMPOUNDS

Brine, Glauber's salt, Sodium carbonate, Sodium chloride, Sodium sulfate, Sodium sulfite, etc.

ION EXCHANGE CHROMATOGRAPHY

Regeneration chemicals of ion exchangers.

and more.



INSTALLATION

PIPE ELBOWS OF 2 INCH AND LARGER

SANDVIK COUPLING CONNECTION



The Compact Process Refractometer PR-23-GC is designed for the general industry small pipeline and bypass line applications. The PR-23-GC sensor is easy to install in the process either directly in a pipe elbow by a Sandvik coupling connection or in a straight pipe via a Wafer flow cell or a Pipe flow cell.

The flangeless Wafer flow cell is a compact alternative to traditional flanged pipe flow cells. The Wafer refers to a flow cell body that is installed between DIN, ANSI or JIS piping flanges with bolts and nuts. The Wafer flow cell is a one-piece body construction with no welds. If the harsh environments or aggressive process fluid require a better material grade against chemical corrosion, higher alloys and special wetted parts materials are available.

Both flow cell mounting designs create optimum flow velocity on the measurement surface providing a good self-cleaning effect. The flow cells have also an optional automatic wash system capability. Intrinsically safe and hazardous area certification is provided for hazardous areas.

STRAIGHT PIPE AND BYPASS LINES

WAFER FLOW CELL (0.5, 1 AND 1.5 INCH)



PIPE FLOW CELL (1 INCH)



DUAL CONNECTIVITY

The Compact Process Refractometer PR-23-GC sensor is factory calibrated to measure refractive index n_D and temperature T in standard units. Each sensor has identical calibration $n_D = 1.32 \dots 1.53$ (corresponding to 0-100 Brix). One or two sensors can be connected to one Indicating transmitter.

Because the PR-23 sensors have identical calibration, and each sensor gives Refractive Index n_D and temperature as outputs, all sensors can be freely interchanged without any inconvenience of optical calibration or parameter changes.

The non-linear conversion from refractive index to concentration units and also temperature compensation are based on standard tables. They are programmed inside the transmitter independently of the sensor.

Our manufacturing process is ISO 9001 certified. We also support the verification within the user's own quality system.

Each sensor is provided with a calibration certificate comparing a set of standard liquids to the actual sensor output. Therefore, the calibration and accuracy can be easily verified on-site with the certified refractive index liquids and the documented verification procedure.

DIGITAL MEASUREMENT PRINCIPLE

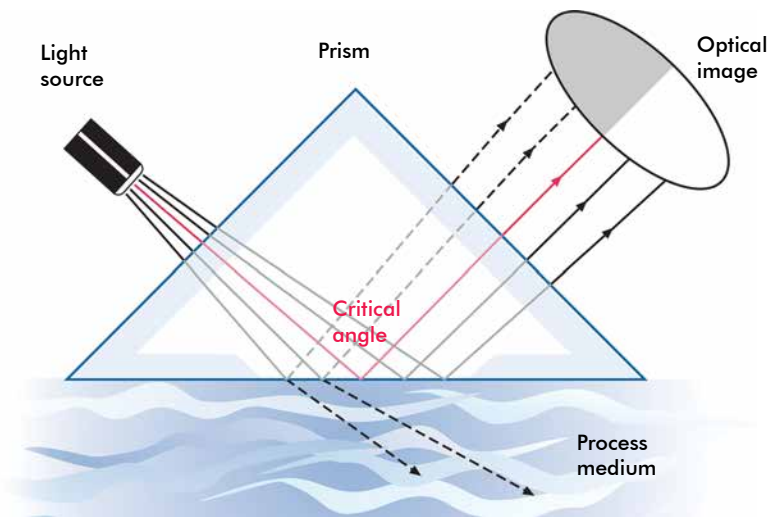

The light source emits light at the interface, between a prism and the process solution, where the rays meet the surface at different angles.

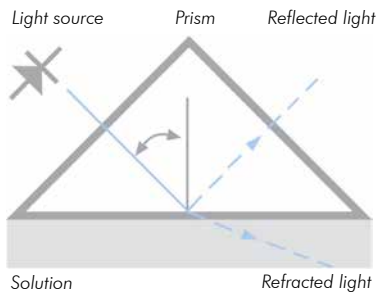

Depending on the angle, some rays undergo a total internal reflection. The rest of the light is refracted into the process solution.

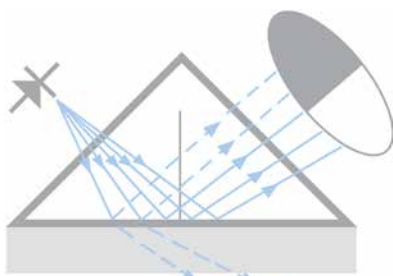

Thus an optical image with a dark sector and a light sector is created.

The angle corresponding to the shadow line is called the Critical Angle of Total Reflection. The Critical Angle is a function of the refractive index and therefore the concentration of the solution.

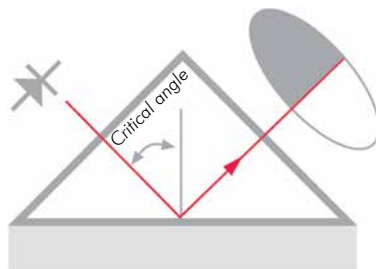

A digital CCD-camera detects the optical image and the shadow line. The camera transforms the optical image point-by-point to an electrical signal. The exact shadow line position is located and the refractive index n_D is determined.

A built-in temperature sensor measures the temperature T on the interface of the process liquid. The indicating transmitter converts the refractive index n_D and temperature T to concentration units.

The diagnostics program ensures that the measurement is reliable.

OPERATION

The Process Refractometer PR-23-GC provides truly accurate means for measuring liquid concentrations and Brix in various process applications. The PR-23-GC Refractometer determines the concentration of dissolved solids by making an optical measurement of a solution's refractive index.

The measurement accuracy is not influenced by particles, bubbles, sugar crystals, seeds, fibres, colour or temperature changes in the process medium. The PR-23-GC Refractometer does not require any recalibration or regular maintenance.

DATA LOGGING VIA ETHERNET

The PR-23-GC Refractometer includes an Ethernet based communications solution which allows connection to computer networks (LAN) and to the Internet. Real-time measurement data and diagnostic information may be obtained through this interface, and this makes it also a valuable service tool for parameter changes and software updates.

Only a cross-over cable and data acquisition software are needed for collecting the data from a PR-23 refractometer. The communication is built on standard protocols (UDP/IP) and we offer ready-to-install software for data acquisition.

This software is expandable if the user wishes to modify the program. Being written in Java, the program is system independent and can be tailored to almost any computing environment.

DESIGN

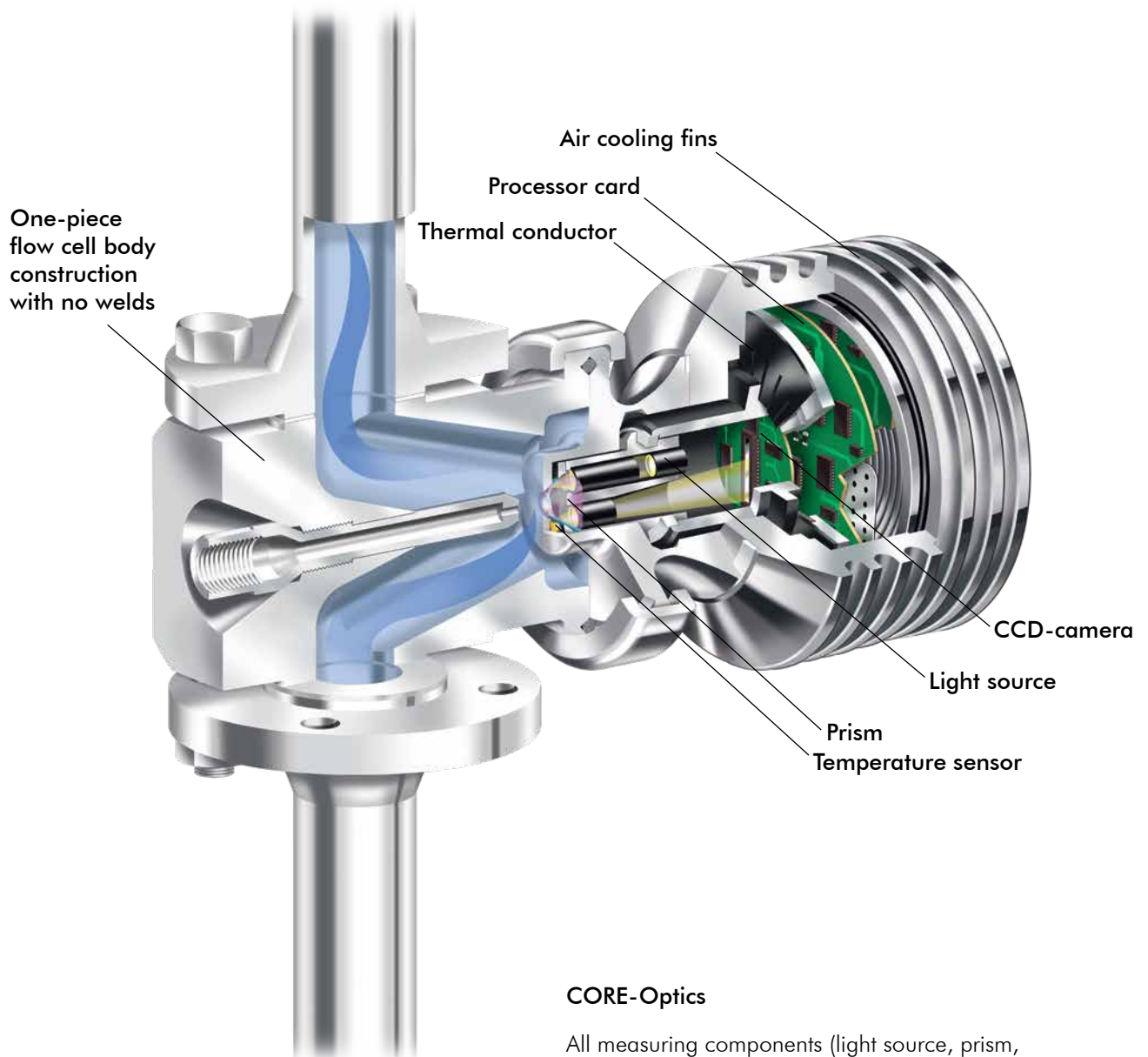

CORE-Optics

All measuring components (light source, prism, temperature sensor and CCD-camera) are in one solid CORE-optics module.

The CORE-optics is mechanically isolated from the influence of external forces and vibrations. The CORE-optics contains no mechanical adjustments.

SPECIFICATIONS

Sensor PR-23-GC with Sandvik coupling L

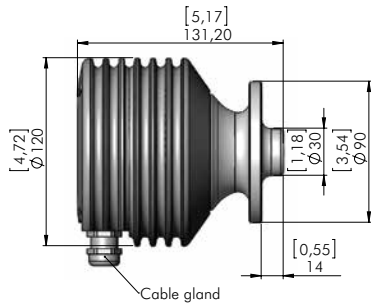

Sensor PR-23-GC with WFC Wafer flow cell (1 inch)

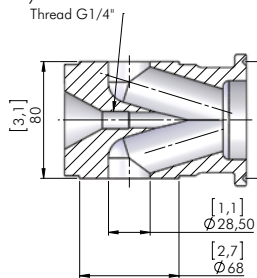

PFC Pipe flow cell

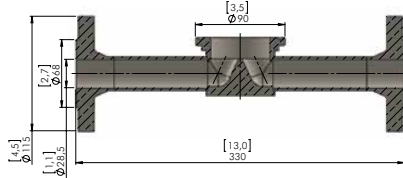

Indicating transmitter DTR

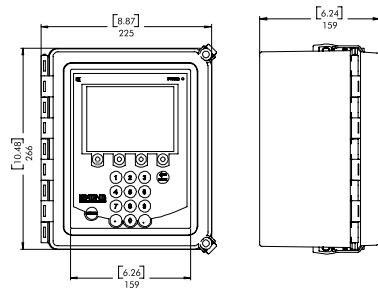

Refractive Index range, standard: Full range, $n_D = 1.3200...1.5300$ (corresponds to 0...100 % b.w.), Sapphire prism

Refractive Index range, options: $n_D = 1.2600...1.4700$, Sapphire prism; $n_D = 1.4100...1.6200$, YAG prism; $n_D = 1.5200...1.7300$, GGG prism

Accuracy: Refractive index $n_D \pm 0.0002$ (corresponds typically to $\pm 0.1\%$ by weight)
Repeatability $n_D \pm 0.0001$ (corresponds typically to $\pm 0.05\%$ by weight)

Speed of response: 1 s undamped, damping time selectable up to 5 min

Calibration: With Cargille standard R.I. liquids over full range of $n_D 1.3200...1.5300$

CORE-Optics: No mechanical adjustments

Digital measurement: 3648 pixel CCD element

Light source: Light emitting diode (LED), 589 nm wavelength, sodium D-line

Temperature sensor: Built-in Pt-1000, linearization according to IEC 751

Temperature compensation: Automatic, mathematical compensation

Instrument verification: According to ISO 9001 quality system and with standard R.I. liquids

Ambient temperature: Sensor: max. 45°C (113°F), min. -40°C (-40°F)
Indicating transmitter: max. 50°C (122°F), min. 0°C (32°F)

SENSOR PR-23-GC AND WAFER FLOW CELL WFC/ PIPE FLOW CELL PFC:

Process connection (in upper elbow of pipe): by Sandvik coupling L 76.1 mm (2.5 inch) for pipe line sizes of 2.5 inch and larger; via reducing ferrule PR-9283 for 2 inch pipes

Wafer flow cell WFC connection (in straight pipe): via Wafer flow cell WFC for pipe line sizes 15 mm (0.5 inch), 25 mm (1 inch) and 40 mm (1.5 inch); Wafer flow cell body mounts between ANSI 150 psi, DIN PN 40 or JIS

Pipe flow cell PFC connection (in straight pipe): via a Pipe flow cell PFC for pipe line sizes of 25 mm (1 inch); Pipe flow process connection ANSI 150 psi, DIN PN 25 or JIS

Process pressure: up to 15 bar (200 psi) at 20°C (70°F)

Process temperature: -40°C...130°C (-40°F...266°F)

Process wetted parts, standard: AISI 316L stainless steel, prism sapphire, prism gaskets PTFE (teflon)

Process wetted parts, options: AISI 904L stainless steel, Alloy 20, Alloy C276, Nickel 200, Titanium ASTM B348 or SAF 2205

Sensor protection class: IP67, Nema 4X

Sensor weight: 4.1 kg (9 lbs)

INDICATING TRANSMITTER DTR:

Display: 320x240 pixel graphical LCD with LED backlight

Keypad: 18 membrane keys

Current output: Two independent current outputs, 4-20 mA, max. load 1000 Ohm, galvanic isolation 1500 VDC or AC (peak), hold function during prism wash

Fieldbus and industrial Ethernet connectivity: Through Fieldbus converter to Modbus/TCP, Modbus RTU and Ethernet/ IP networks

Power: AC input 100-240 VAC/50-60 Hz, optional 24 VDC, 30 VA

Alarms/Wash relays: Two built-in signal relays, max. 250 V/3 A

Sensor connectivity: One or two sensors can be connected to the DTR. Sensors independent of each other: two parameter sets usable in different applications. Two current outputs configurable independently to indicate process concentration or temperature of either sensor.

Transmitter protection class: Polycarbonate enclosure IP66, Type 4X (Indoor use); AISI 304 Stainless steel enclosure IP66 (Indoor use).

Indicating transmitter weight: 4.5 kg (10 lbs)

INTERCONNECTING CABLE: IEC 61158-2 compliant two-wire cable

Interconnecting cable length: Standard 10 m (33 ft), max. 200 m (660 ft)

OPTIONS: Prism wash, Intrinsic safety and hazardous area approvals, cable fittings to the indicating transmitter: European cable glands M20x1.5 or US conduit hubs

PATENTS: see www.kpatents.com

ORDERING INFORMATION:

- Sensor type and process connection
- Desired scale
- Properties of process solution
- Process temperature range
- Process pipe size
- Process flow rate
- Supply voltage and frequency
- Options and accessories

VAISALA

www.vaisala.com

Please contact us at
www.vaisala.com/requestinfo

Ref. B211887EN-A © Vaisala 2020

We reserve right to technical alterations.

A PROCESS REFRACTOMETER
FOR CONCENTRATION
MEASUREMENT OF LIQUIDS

VAISALA



Vaisala K-PATENTS® Process Refractometer PR-23-GP

TYPICAL APPLICATIONS

CHEMICALS

Acetic acid, Acrylate, Amine oxide, Amino acid, Ammonium fluoride, Ammonium hydroxide, Ammonium nitrate, Ammonium sulphate, Caustic soda, Cellulose derivatives, Citric acid, Copper chloride, Chromium trioxide (or Chromic acid), Ethylene glycol, Formaldehyde, Formic acid, Glycerol, Hydrogen peroxide, Iron chloride, Lactic acid, Lubricating oils, Nickel chloride, Nitric acid, Oleum, Polyamides, Polycarbonates, Polyethylene, Resins, Sodium bicarbonate, Sodium dichromate, Sodium gluconate, Sodium hydroxide, Styrenes, Sulphuric acid, Urea, etc.

PLASTICS AND FIBERS

Acetate, Acrylics, Adipic acid, Caprolactam, Cyclohexanol, Cyclohexanon, Dimethylterephthalate, Dimethylformamide, Fiberglass, Hexamethylene diamine, Nylon salt, Polyamides, Polyesters, Rayon, Spandex, Vinyls. Finishing, coating and dyeing mediums of textiles.

PULP AND PAPER INDUSTRY

Alum, Black liquor, CMC, Latex, Sizing chemicals and binders, Starch, PVA, Retention chemicals.

SALTS AND SODIUM COMPOUNDS

Brine, Glauber's salt, Sodium carbonate, Sodium chloride, Sodium sulfate, Sodium sulfite, etc.

SOAP AND DETERGENTS

Fatty acids, Fatty alcohols, Caustic potash, Caustic soda, Glycerol, Salt, Soda ash, Sodium bicarbonate

STARCH SWEETENERS

Fructose, high fructose corn syrup, sorbitol, dextrose, glucose, xylose, maltose, mannitol, lactitol, aspartame, flavors. Supersaturation and seeding point control of fructose and dextrose syrups, cooling crystallizer, precrystallizer, main crystallizer.

SUGAR

Sucrose, affination, extraction, press water, thick juice, thin juice, vacuum pan, molasses, mother liquor. Supersaturation and seeding point control, cooling crystallizer, precrystallizer, main crystallizer.



INSTALLATION

MEDIUM AND LARGE PIPES

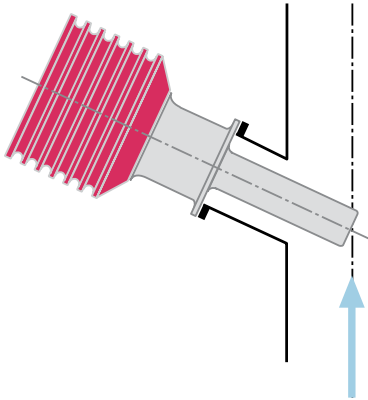

PIPES 2" OR SMALLER

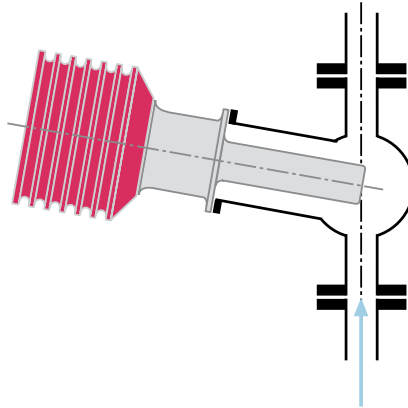

VESSELS

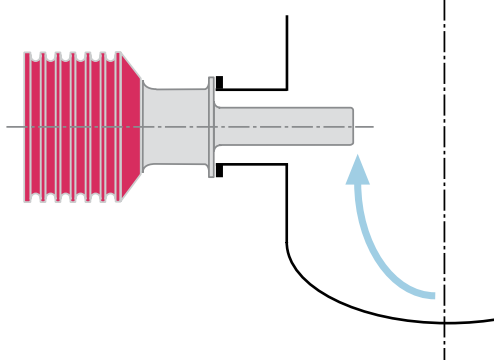
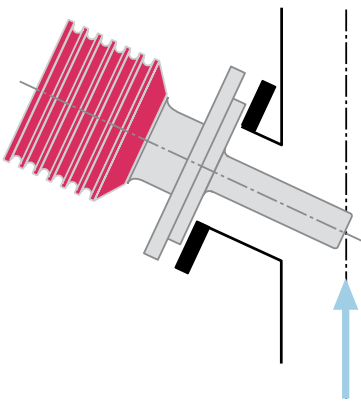

DUAL CONNECTIVITY

The Process Refractometer PR-23-GP sensor is factory calibrated to measure refractive index n_D and temperature T in standard units. Each sensor has identical calibration $n_D=1.32...1.53$ (corresponding to 0-100 Brix). One or two sensors can be connected to one Indicating transmitter.

Because the PR-23 sensors have identical calibration, and each sensor gives Refractive Index n_D and temperature as output, all sensors can be freely interchanged without any inconvenience of optical calibration or parameter changes.

The non-linear conversion from refractive index to concentration units and also temperature compensation are based on standard tables. They are programmed inside the transmitter independently of the sensor.

Our manufacturing process is ISO 9001 certified. We also support the verification within the user's own quality system.

Each sensor is provided with a calibration certificate comparing a set of standard liquids to the actual sensor output. Therefore, the calibration and accuracy can be easily verified on-site with the certified refractive index liquids and our documented verification procedure.

DIGITAL MEASUREMENT PRINCIPLE

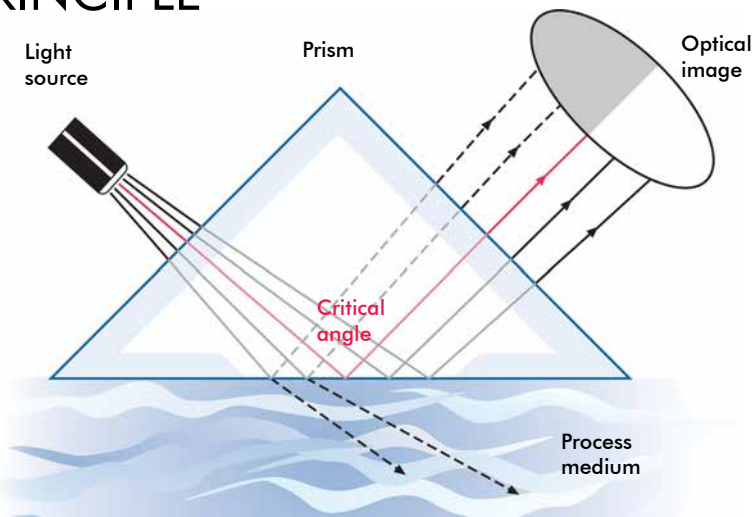

The light source emits light at the interface, between a prism and the process solution, where the rays meet the surface at different angles.

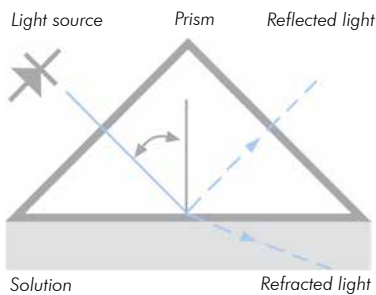

Depending on the angle, some rays undergo a total internal reflection. The rest of the light is refracted into the process solution.

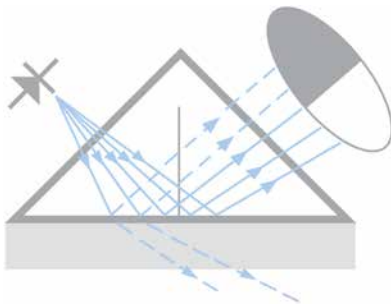

Thus an optical image with a dark sector and a light sector is created.

The angle corresponding to the shadow line is called the Critical Angle of Total Reflection. The Critical Angle is a function of the refractive index and therefore the concentration of the solution.

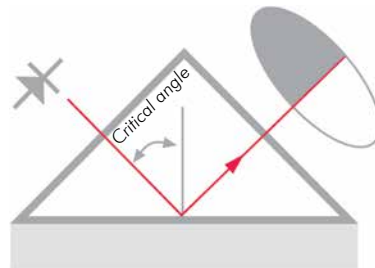

A digital CCD-camera detects the optical image and the shadow line. The camera transforms the optical image point-by-point to an electrical signal. The exact shadow line position is located and the refractive index n_D is determined.

A built-in temperature sensor measures the temperature T on the interface of the process liquid. The indicating transmitter converts the refractive index n_D and temperature T to concentration units.

The diagnostics program ensures that the measurement is reliable.

OPERATION

The Process Refractometer PR-23-GP provides truly accurate means for measuring liquid concentrations and Brix in various process applications. The PR-23-GP refractometer determines the concentration of dissolved solids by making an optical measurement of a solution's refractive index.

The measurement accuracy is not influenced by particles, bubbles, sugar crystals, seeds, fibres, colour or temperature changes in the process medium. Refractometer PR-23-GP does not require any recalibration or regular maintenance.

DATA LOGGING VIA ETHERNET

Refractometer PR-23-GP includes an Ethernet based communications solution which allows connection to computer networks (LAN) and to the Internet. Real-time measurement data and diagnostic information may be obtained through this interface, and this makes it also a valuable service tool for parameter changes and software updates.

Only a cross-over cable and data acquisition software are needed for collecting the data from a PR-23 refractometer. The communication is built on standard protocols (UDP/IP) and we offer ready-to-install software for data acquisition.

Our data acquisition software is expandable in case the user wants to modify the program. The program is written in Java and thus system independent. It can be tailored to almost any computing environment.

DESIGN

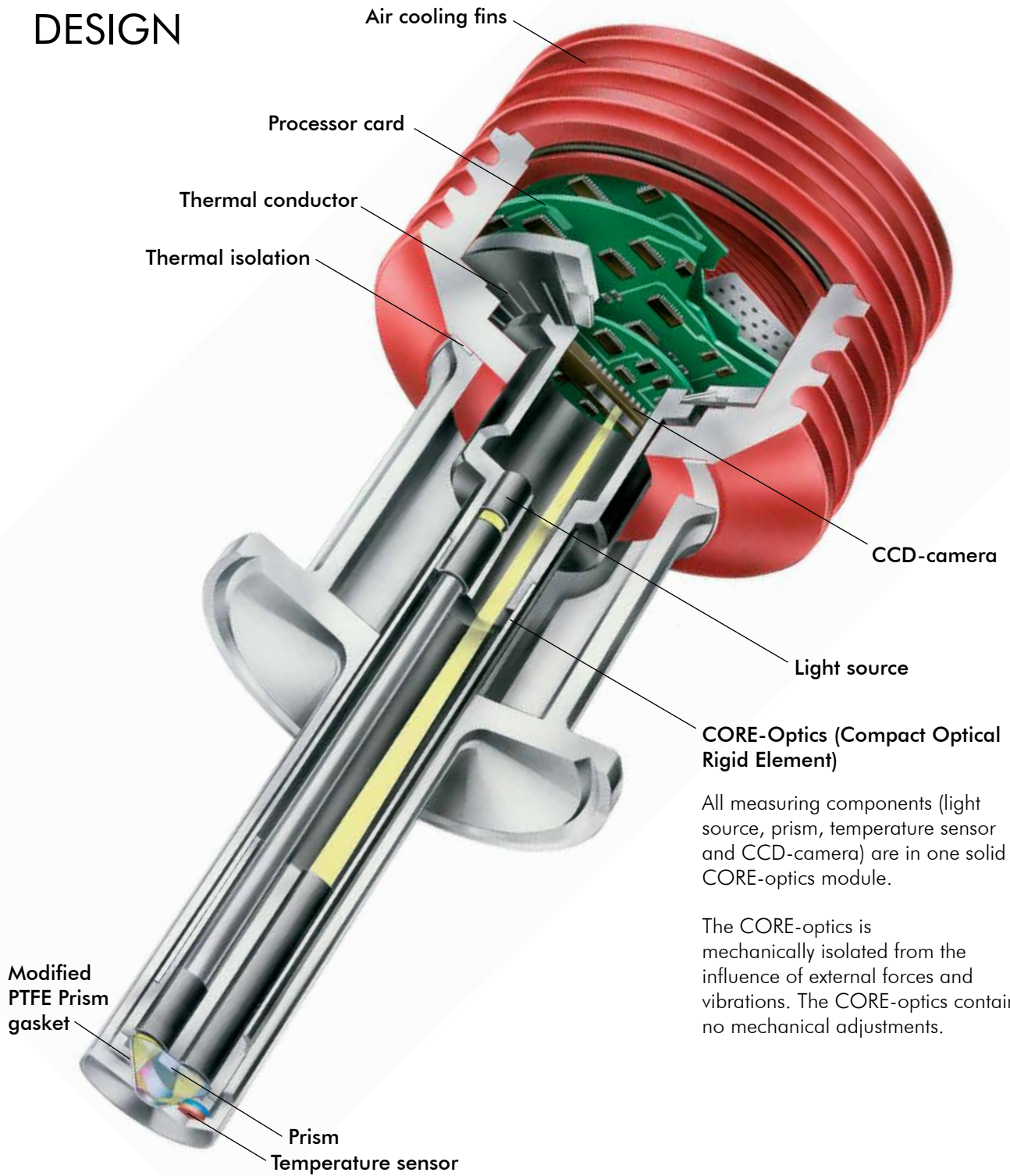

All measuring components (light source, prism, temperature sensor and CCD-camera) are in one solid CORE-optics module.

The CORE-optics is mechanically isolated from the influence of external forces and vibrations. The CORE-optics contains no mechanical adjustments.

SPECIFICATIONS

Sensor PR-23-GP with Sandvik coupling L

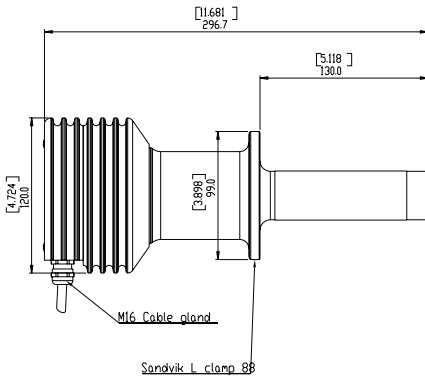

Sensor PR-23-GP with ANSI/DIN/JIS flange

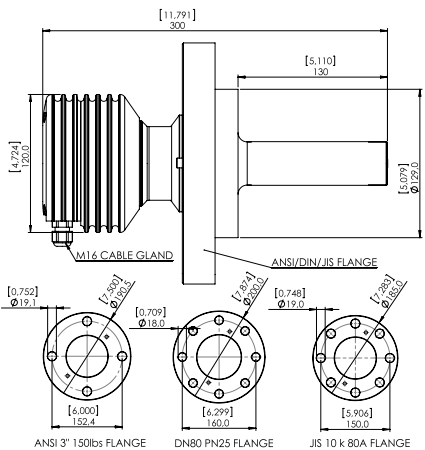

Indicating transmitter DTR

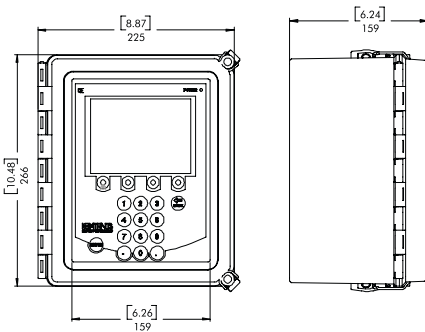

Refractive Index range, standard:	Full range, $n_D = 1.3200...1.5300$ (corresponds to 0...100 % b.w.)
Accuracy:	Refractive index $n_D \pm 0.0002$ (corresponds typically to $\pm 0.1\%$ by weight) Repeatability $n_D \pm 0.0001$ (corresponds typically to $\pm 0.05\%$ by weight)
Speed of response:	1 s undamped, damping time selectable up to 5 min
Calibration:	With Cargille standard R.I. liquids over full range of $n_D 1.3200...1.5300$
CORE-Optics:	No mechanical adjustments
Digital measurement:	3648 pixel CCD element
Light source:	Light emitting diode (LED), 589 nm wavelength, sodium D-line
Temperature sensor:	Built-in Pt-1000, linearization according to IEC 751
Temperature compensation:	Automatic, digital compensation
Instrument verification:	With NIST traceable Cargille standard R.I. liquids. A transmitter guided procedure over Ethernet including a printable verification report
Ambient temperature:	Sensor: max. 45°C (113°F), min. -40°C (-40°F) Indicating transmitter: max. 50°C (122°F), min. 0°C (32°F)

SENSOR PR-23-GP:

Process connection:	Sandvik coupling L 88 mm/DIN-flange 2656, DN80 PN25/ANSI-flange 150 lbs, 3 inch/JIS-flange 10k 80A/Line sizes less than 2" via Pipe flowcell
Process pressure:	up to 25 bar (350 psi)
Process temperature:	-40°C...150°C (-40°F...302°F)
Process wetted parts, standard:	AISI 316L stainless steel, prism spinel, prism gaskets modified PTFE (Teflon)
Sensor protection class:	IP67, Nema 4X
Sensor weight:	Sandvik coupling L 3.8 kg (8.4 lbs), Flange DIN/ANSI/JIS 6.6 kg (14.1 lbs)

INDICATING TRANSMITTER DTR:

Display:	320x240 pixel graphical LCD with LED backlight
Keypad:	18 membrane keys
Current output:	Two independent current outputs, 4-20 mA, max. load 1000 Ohm, galvanic isolation 1500 VDC or AC (peak), hold function during prism wash
Fieldbus and industrial Ethernet connectivity:	Through Fieldbus converter to Modbus/TCP, Modbus RTU and Ethernet/ IP networks
Power:	AC input 100-240 VAC/50-60 Hz, optional 24 VDC, 30 VA
Alarms/Wash relays:	Two built-in signal relays, max. 250 V/3 A
Sensor connectivity:	One or two sensors can be connected to the DTR. Sensors independent of each other: own parameter sets and usable in different applications. Two current outputs configurable independently to indicate process concentration or temperature of either sensor.

Transmitter protection class:	Polycarbonate enclosure IP66/ Type 4X (Indoor use); AISI Stainless steel enclosure IP66 (Indoor use)
Indicating transmitter weight:	4.5 kg (10 lbs)
INTERCONNECTING CABLE:	IEC 61158-2 compliant two-wire cable
Interconnecting cable length:	Standard 10 m (33 ft), max. 200 m (660 ft)
OPTIONS:	Stainless steel sensor housing, special wetted parts materials, extended refractive index range limits, prism wash, intrinsic safety and hazardous area approvals, cable fittings to the indicating transmitter: European cable glands M20x1.5 or US conduit hubs
PATENTS:	See www.kpatents.com

ORDERING INFORMATION:

- Sensor type and process connection
- Desired scale
- Properties of process solution
- Process temperature range
- Process pipe size
- Process flow rate
- Supply voltage and frequency
- Options and accessories



www.vaisala.com

Please contact us at
www.vaisala.com/requestinfo

Ref. B211886EN-A © Vaisala 2020

We reserve right to technical alterations.